

STA Sectional Overhead Door Operators



Product Description

The STA sectional overhead door operator has a 0.55kW, 400V three phase motor.

Alternatively, a 0.3kW, 240V single phase version is available.

These models are available with hand crank, floor level hand chain & high level hand chain systems, which enables the door to be manually opened & closed when required.

Available with pre-wired Mini-Basic or Mini Standard Starter.

Developed to make installation easy and simple.

Optional 'Spring Sensor' Function available on request.

	400V 3 Phase Operators	230v 1 Phase Operators
Torque (Nm)	100 (140 Peak)	70
Power (Kw)	0.55	0.3
Output Speed (rpm)	24	24
Shaft Diameter (mm)	25.4	25.4
Voltage/Phase	400/3	230/1
Current (amps)	1.8	4.7
Frequency (Hz)	50	50
Limit Turns	22	22
Protection (IP)	54	54

Please Contact Our Sales Department On 01928 579050 For Further Information

Product Dimensions

STA 3ph c/w Floor Level Hand Chain Mechanism—Note: Vertical Mount Option Only Available.

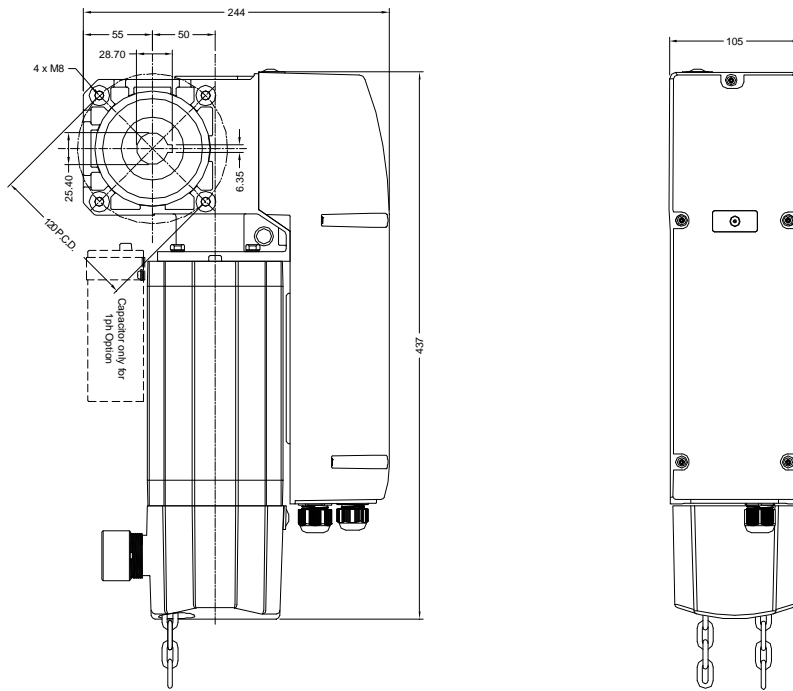

STA 3ph c/w High Level Hand Chain—Note: Horizontal Mount Option Only Available.

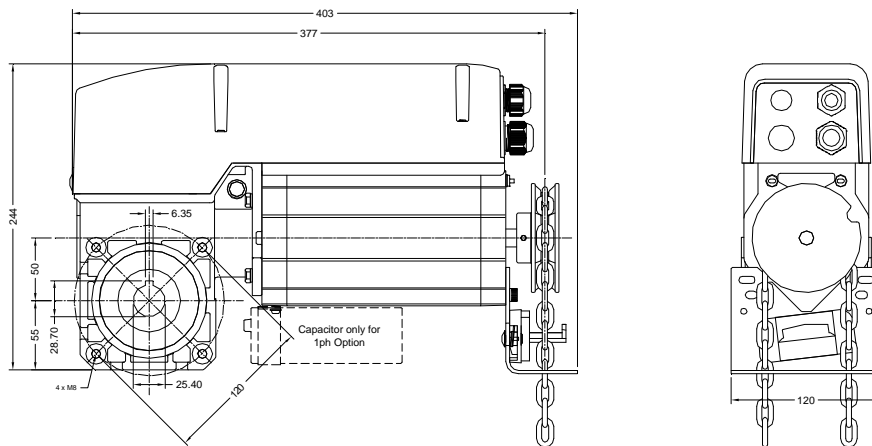

STA 3ph c/w Disengage Mechanism—Note: Vertical or Horizontal Mount Option Available.

